

Features:

1. Explosion proof : Ex mb 11 T4, Ex mD 21 T135 .
2. Pilot operated, high flow rate and low electric power consumption only 5.2 watts.
3. Suitable for Air, Inert gases, Water, Kerosene oil, Light oil (Below 50 cst).
4. Operating pressure range from 0.1 kgf/cm² ~ 16 kgf/cm², quick acting, durable usage.
5. Piping is simple and convenient, applicable to the upright pipe or a horizontal pipe connected unrestricted.

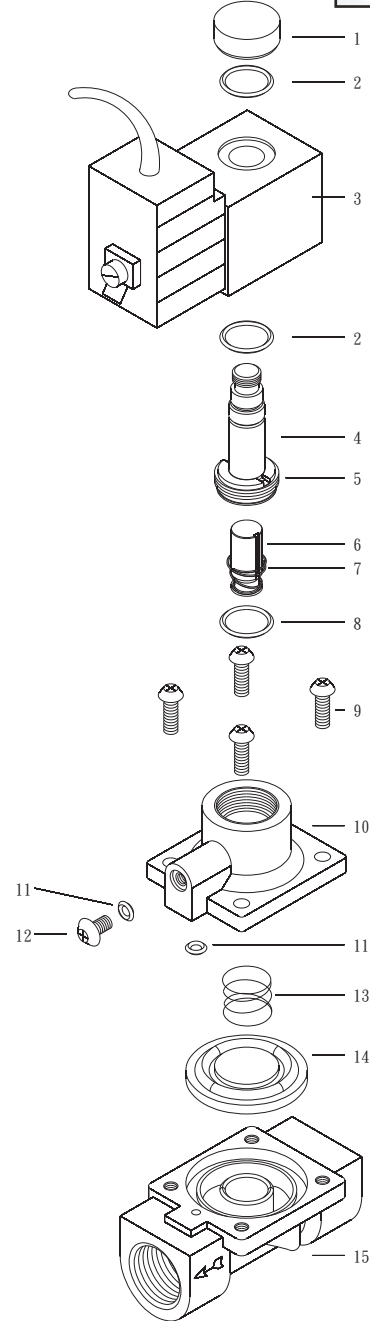
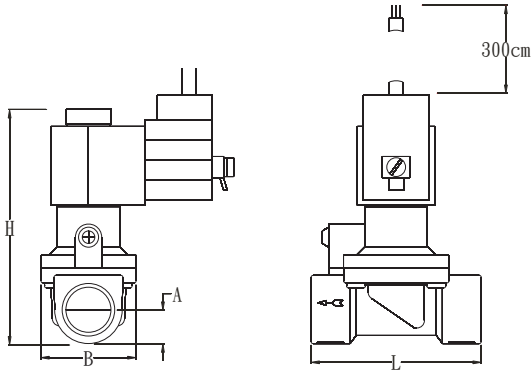

Parts , Material Table

No.	Parts	Material Specifications
1	Nut	Aluminium
2	O Ring	NBR
3	Coil's Ass'y	
4	Plunger's Tube	SUS304, KM-31
5	Plunger's Tube Nut	Zn
6	Plunger	KM-31
7	Plunger Spring	SUS 304
8	O Ring	NBR EPDM VITON
9	Bolt	SUS304
10	Valve Bonnet	BSBF or SCS14
11	O Ring	NBR EPDM VITON
12	Screw	SUS304
13	Diaphragm Spring	SUS 304
14	Diaphragm	NBR EPDM VITON
15	Valve body	BSBF or SCS14

Valve Selection and Performance Chart

Model	Port Size	Orifice (mm)	Maximum Using Pressure (kg*f/cm ²)		Power Consumption	Cv Value	Maximum Fluid Temp	Dimensions (mm)				Weight (g)
			Inert Gases	Water Kerosene oil /Light oil				L	H	B	A	
MA-P10-EXP	PT 3/8"	12	16	15	5.2	2.6	90 °C	69	92	38	13.5	685
MA-P15-EXP	PT 1/2"											

*NPT thread on request.