



Features:

1. Suitable for air, inert gases, vacuum (10TORR), water, kerosene oil, and oil (Below 50cst).
2. Direct acting, wide operating pressure range from 10 TORR up to 30kg*/cm², fast response and excellent service life.
3. Can be mounted in vertical and horizontal position.

Model	Connection	Orifice (mm)	Max. (Kg*f/cm ²)		Power Consumption VA	Cv Value	Max. Media Temp.	Size (mm)			Mounting hole (mm)	
			Air	Water Oil				L	H	h	A	
MK2A-5016-8(10)	PT 1/4"	1.6	50	30	22	0.09	90 °C	35	65	54	18	2-M4 (1/4")
MK2A-4020-8(10)		2	40	25		0.15						
MK2A-2030-8(10)	PT 3/8"	3	20	14		0.25						
MK2A-1045-8(10)		4.5	10	7		0.35		42	67	56	24	2-M5 (3/8")

- * 1/4" on request.
- * NPT on request.
- * SUS304 valve body on request.

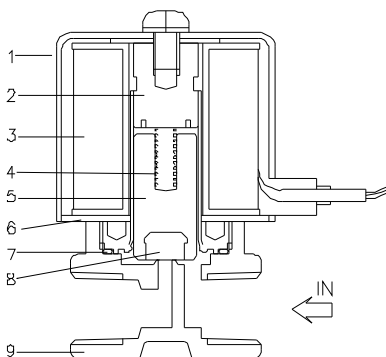
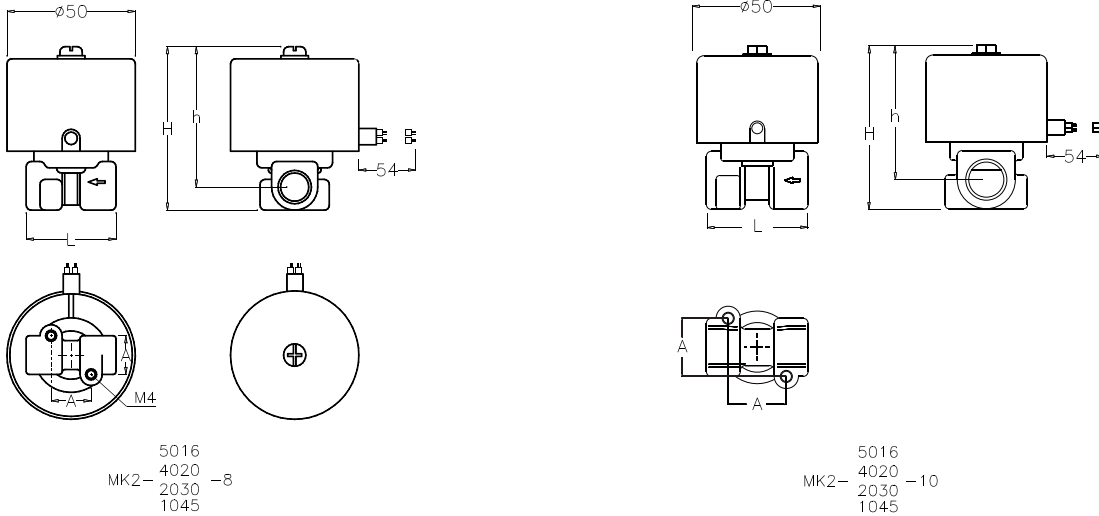

NO.	Descriptions	Material
1	Coil bonnet	SPC
2	Plunger tube unit	SUS304, KM-31
3	Solenoid coil	B Class
4	Plunger spring	SUS304
5	Plunger	KM-31
6	Spacer	SPC
7	O ring	NBR
8	Plunger seat	H NBR
9	Valve body	BSBF(* SUS303L)

* SUS303L on request.