

# MK 驅動器外觀尺寸圖

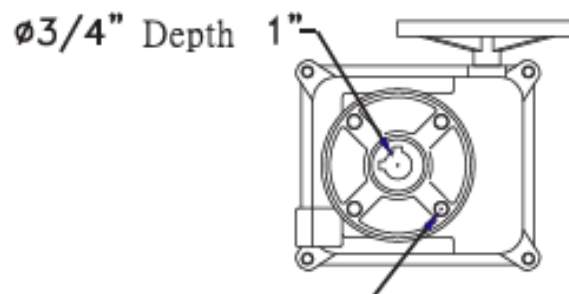

MK21

Unit: mm

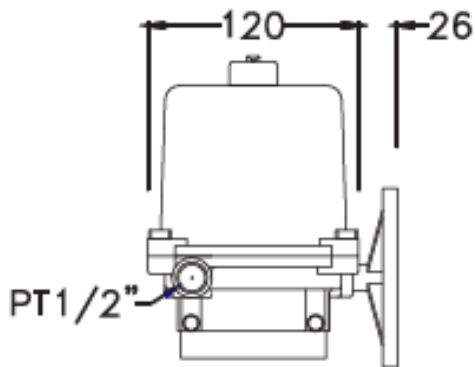
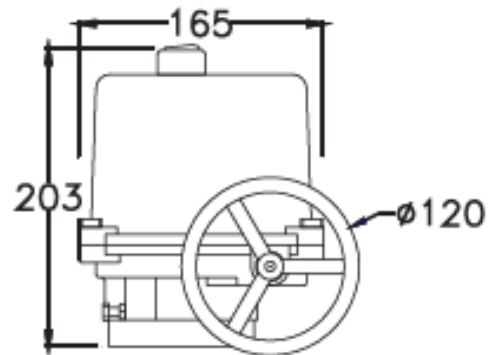
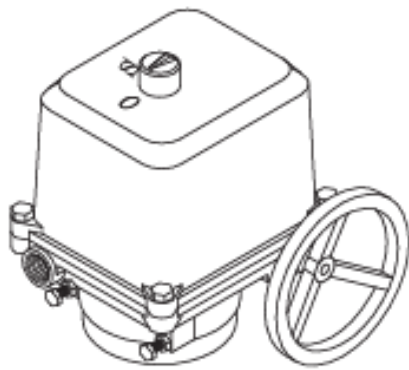

4 OFF 3/8-16UNC ON 82.5 PCD

# MK 驅動器外觀尺寸圖



MK22

Unit: mm

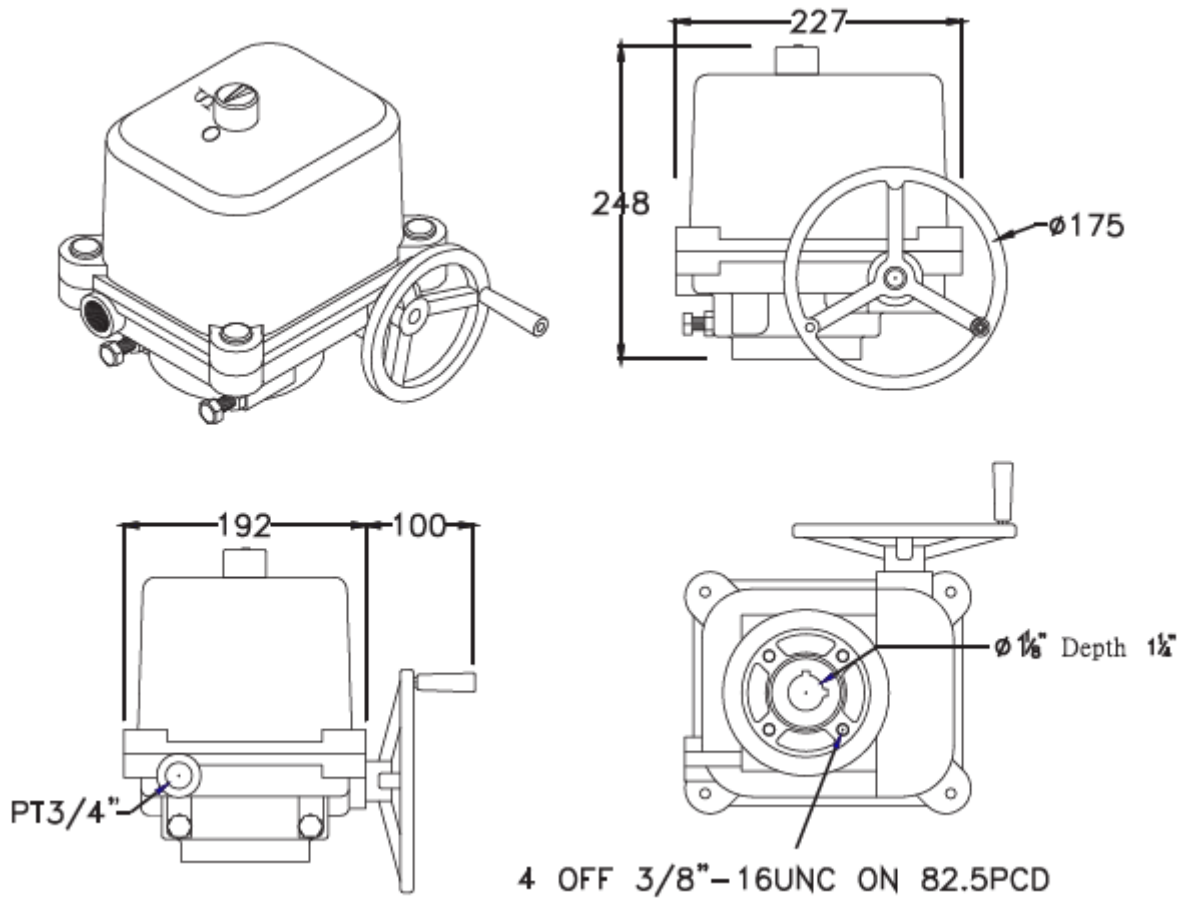

# MK 驅動器外觀尺寸圖



MK23

Unit: mm

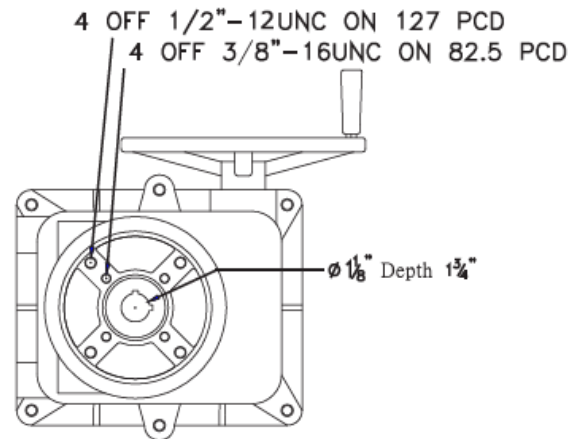
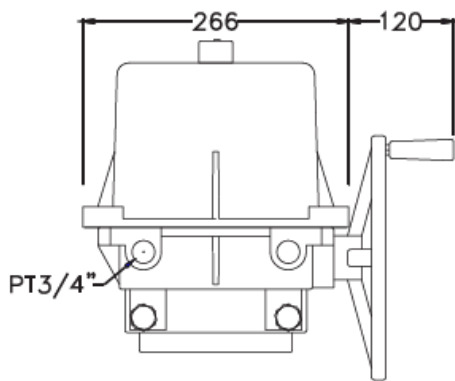
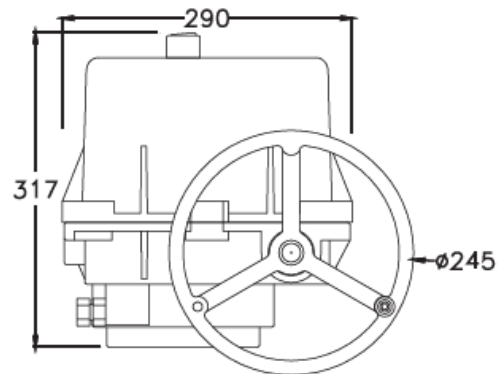
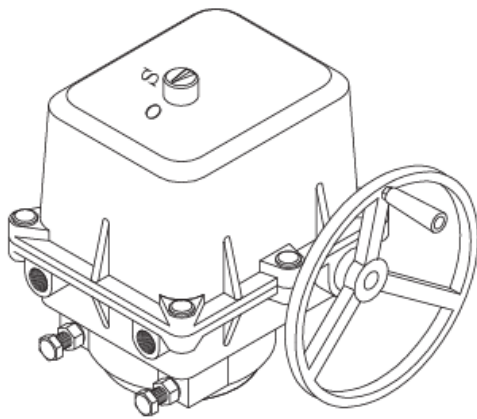

# MK 驅動器外觀尺寸圖



MK24

Unit: mm

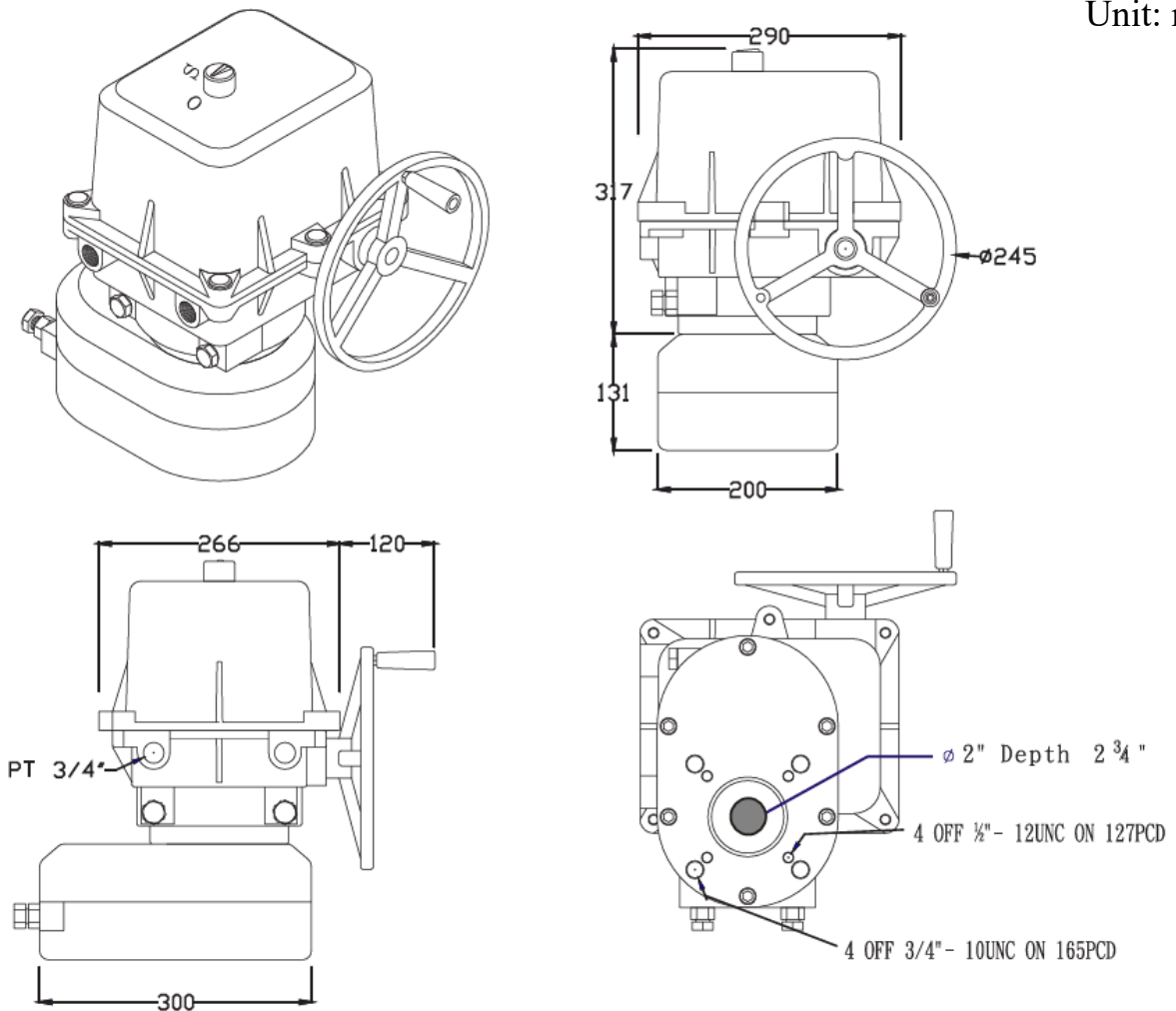

# MK 驅動器外觀尺寸圖

## 組件圖

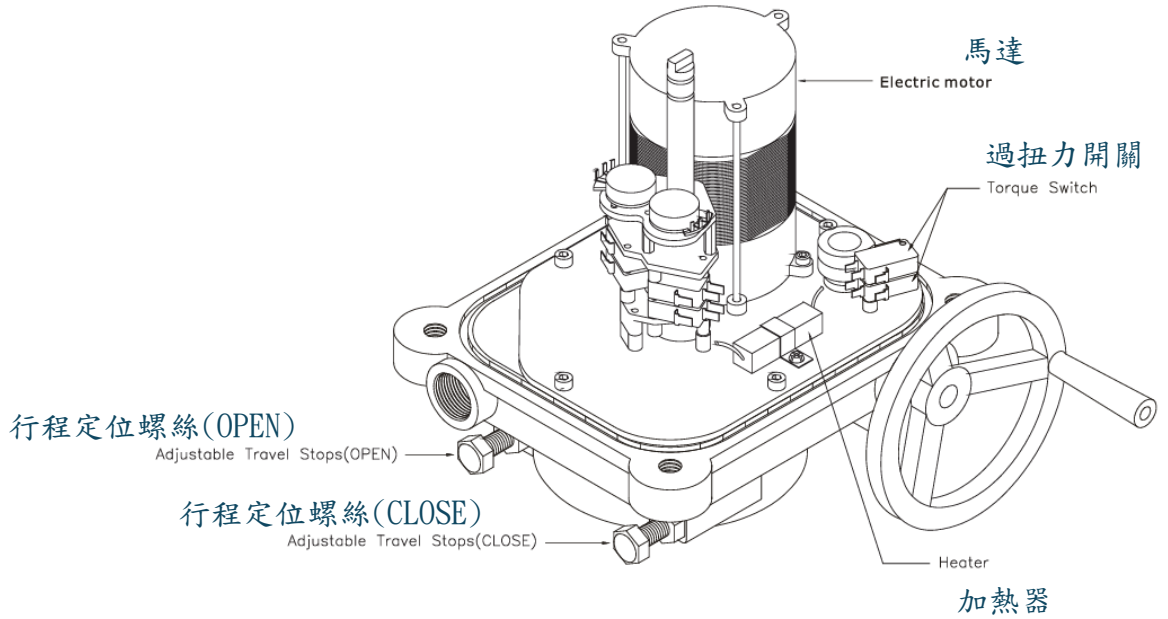

\* 記號標示為選購配件

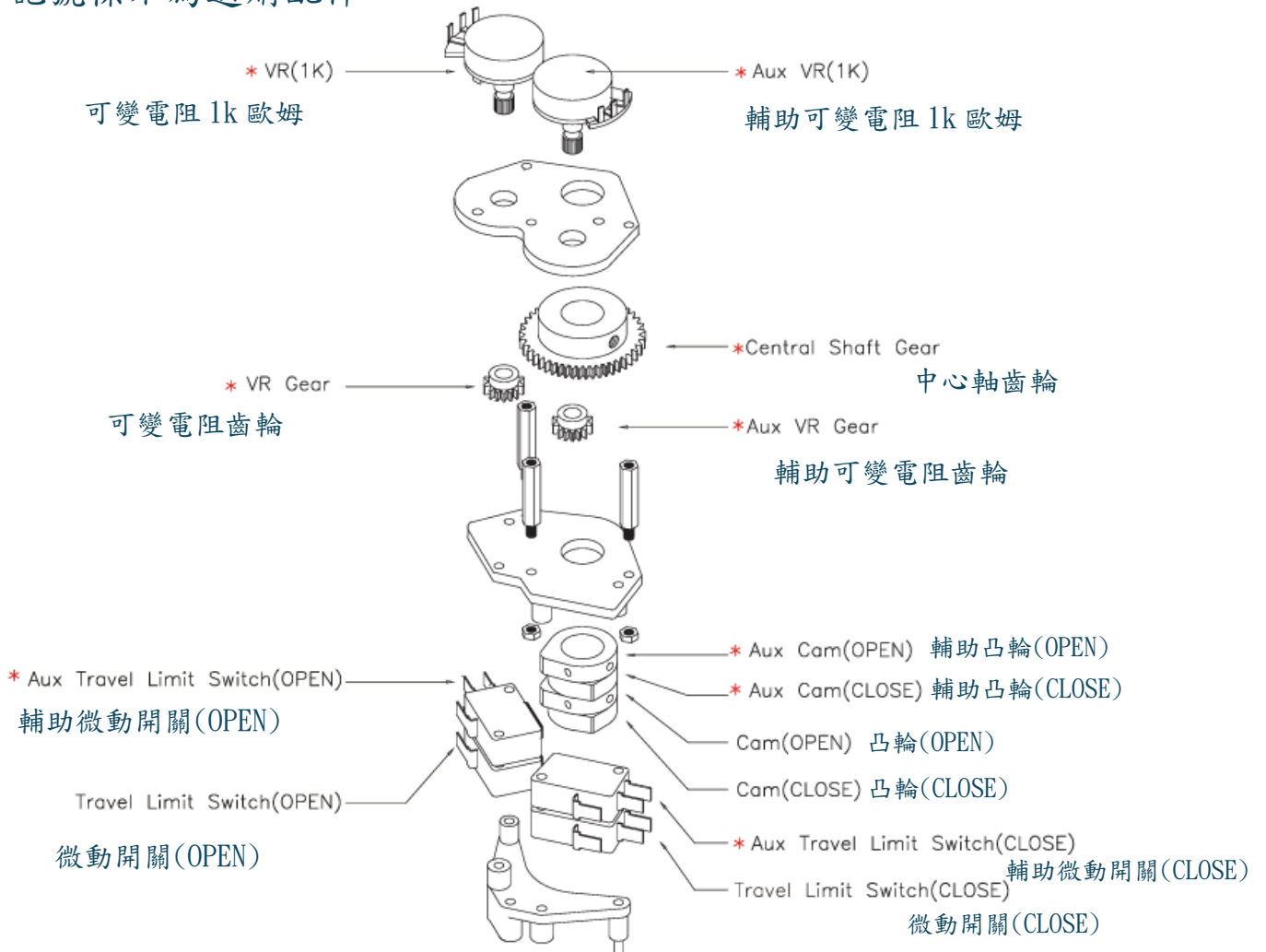

# MK 驅動器外觀尺寸圖

## 組件圖

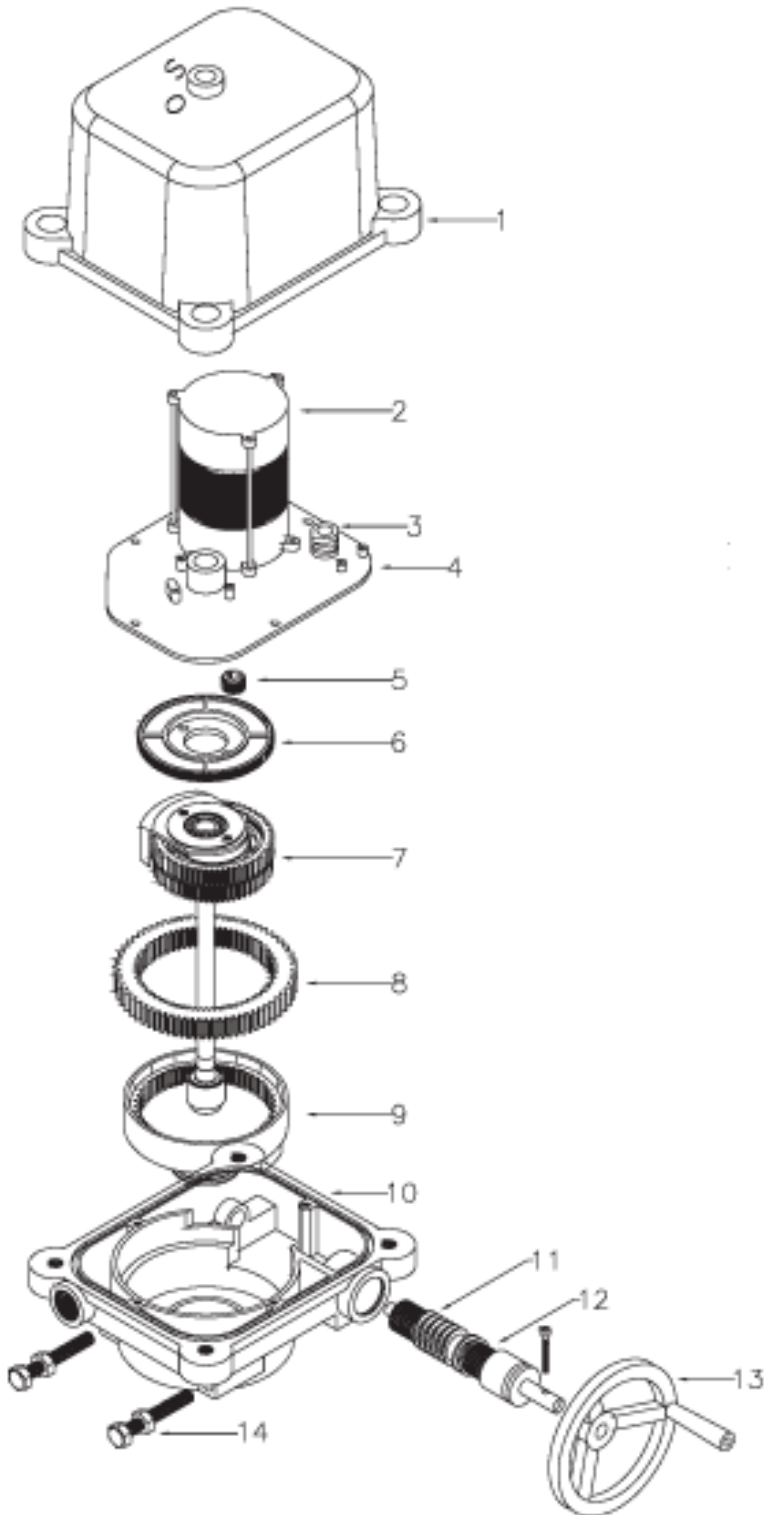

No.	名稱
1	上蓋
2	馬達
3	扭力凸輪
4	中板
5	馬達齒輪
6	平行減速齒輪
7	偏心齒輪組
8	內外齒輪
9	主軸齒輪, 指示桿
10	齒輪箱
11	蝸齒輪
12	錐盤彈簧
13	手輪
14	定位螺絲

